

Download the most up-to-date version
at rexnord.com/documentation



OUR INNOVATION MOVES



Rexnord Conveying Solutions

FOR BUCKET ELEVATORS



Bucket-Elevator Inspection Service

- Full, efficient, expert inspection service.
- Record and documentation of all components in use, including wear condition.
- Full visual and manual inspection of components including chain, wheels, buckets, bearings, and housings.
- Includes no-cost inspection report with recommendations and offers upon request.



Product Overview



Rex-Single Strand-Chain

Rex Single-Strand Chain

At Rexnord®, we're a world market leader in power transmission. All components of our bucket-elevator chains are precisely aligned to ensure optimal lifetime service and reliability. We offer a vast range of conveyor chains, attachments, and components suited for all applications and requirements.

Chain Type	ER102	ER111	ER856	ER956	ER857	ER958	ER859	ER864	ER984
Pitch (mm)	101,6	120,9	152,4	152,4	152,4	152,4	152,4	177,8	177,8
Bushing Ø (mm)	25,4	36,6	44,5	44,5	44,5	50,8	60,5	60,5	63,5
Inner width (mm)	54,1	66,8	76,2	76,2	76,2	76,2	95,3	95,3	95,3



Buckets

Buckets

Rexnord offers a wide selection of bucket styles in fabricated steel with optional wear lips. Buckets are available in "AC," "Mill Duty," and "DIN" versions. Our engineers have designed our buckets with over 60 years of practical elevator application experience.

For more information about Rexnord and Link-Belt® Engineered Steel Chains, see *Catalog 5050* in our Documentation Library.





Product Overview

Shaft

Available in standard or special designs, according to sample or drawing.



Clamping device (Tollok®)

Reliable clamping element for shaft and body.



Body

Standard body from 16" to 35".

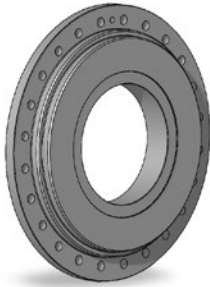

Segmental-Traction Wheel or Sprocket

Available from 3 to 6 segments, and sizes from 20" to 49".

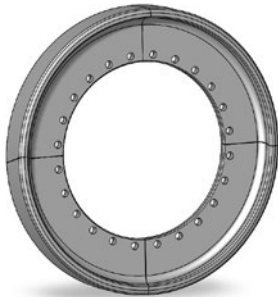

Head and Foot Section

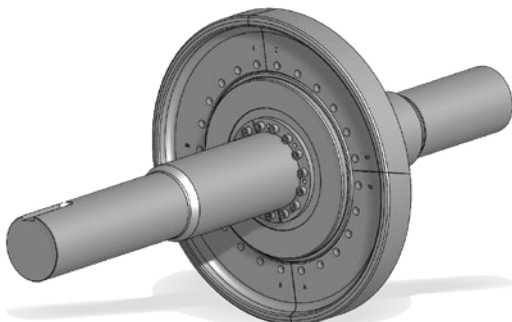

Rex-Retrofit

MODIFICATION OPTION FROM DOUBLE-STRAND CHAIN OR BELT TO REXNORD SINGLE-STRAND CHAIN.

Eliminate common problems by converting from a double-strand chain or belt to a more reliable single-strand chain. At Rexnord, we provide planning, calculation, and support for a simple conversion to a single-strand chain system for lower maintenance and increased dependability.



Double-Strand Elevator



Double-Strand Elevator



Belt Elevator





Installation Supervision

COMPLETE INSTALLATION SUPERVISION

Expert support for chain replacement, shortening, and more.

- Professional assembly of the chain sections.
- Assembly of the head and foot to Rexnord specifications.
- Parallel alignment of head and foot sections.
- Precision handling and lifting of the chain.
- Correct assembly of the chain in the elevator.
- Use of our professional chain assembly tool: LinkMaster.
- Test run to ensure full operability.



LinkMaster

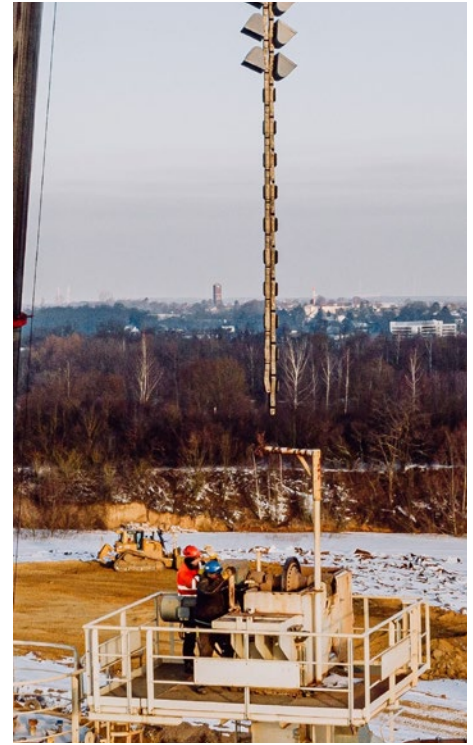

Supervision – Hanging the chain



Bucket Elevator Systems



COOPERATION REXNORD KETTE WITH GERMAN-OEM

- All internal components from Rexnord.
- Precision plant engineering of housing.
- Large, accessible maintenance doors and windows.
- Emergency emptying door.
- Reinforced sheets: base 0.394" (10mm) + galvanized, head 0.315" (8mm), spacers .236" (6mm).
- User-friendly drive unit.
- Special requests and customization options are available.



Questions? Email us at ce-support@rexnord.com



rexnord.com

Contact us – visit rexnord.com/contact



OUR INNOVATION MOVES